

### Applications

Separation and lifting of horizontal plates (individual or bundles).

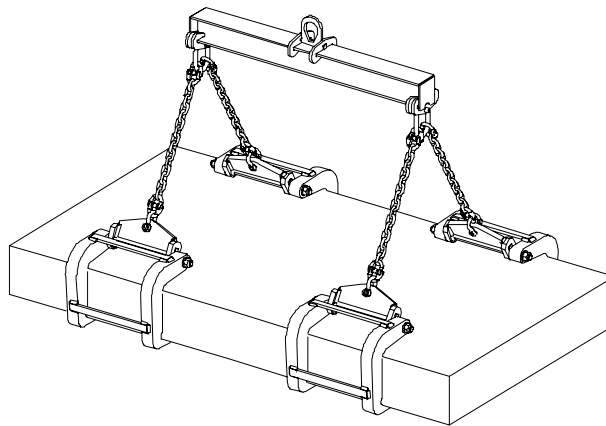
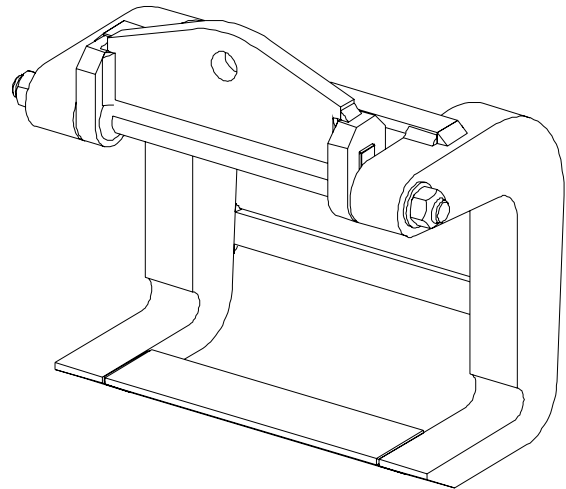
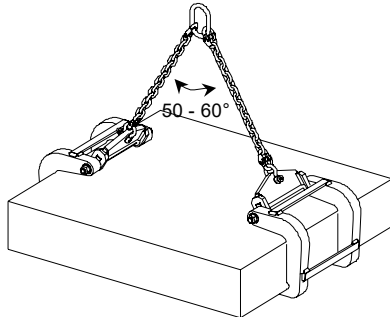

### Description

These double hooks avoid the use of a lifting beam. Their pivoting eye permits to pull in the sling direction always ; plate bending is reduced thanks to the large load bearing surface. The positioning is made easier thanks to the handle. Slings not provided.

### Functioning

Use in pairs with a 2-legged sling.  
Fit the load into the hooks, making sure the latters are evenly distributed and perform lifting.  
Sheets may be separated thanks to the hooks' sharp end.

### Important instructions

- The load must always be driven home into the throat of the hooks.
- Load minimum width 390 mm.
- Adhere to a sling angle included between 50° and 60° (ie ½ sling angle included between 25° and 30°).
- According to the load's length and weight, provide 1 or more pair(s) of hooks to perform lifting.
- Do not use for separating fragile loads.
- Separate only 1 plate at a time.
- Working temperature: -20° to +100°C.

**General characteristics**

- Manufactured without load bearing welds.
- Hot epoxy coating.
- Safety factor: 3 in accordance with the EN 13155.2003 norm.
- Product conforms to the French regulation, in particular the decree of 01/03/2004 relating to the check on lifting devices and the European Directive n°98/37.
- Product with EC marking and delivered with a declaration of conformity and instructions for use.

**Dimensional characteristics**

HR shackles to be used	Ref.	Group code	WLL/ pair kg	Opening	A	B	C	E	F	G	I	J	K	Sling angle		Min chain* Ø	Weight/ pair kg
														min	max		
6t5	QX10 120	50708	10 000	120	250	27	317	135	30	60	50	20	390	50°	60°	18	60
6t5	QX10 210	50718	10 000	210	285	27	384	135	30	60	50	20	390	50°	60°	18	76

\* provide a 2-legged chain sling grade 80 per pair of hooks

Dimensions in mm

