







- 
 Für extrem kleine Kurvenradien
 Developed for extreme small curved beams
 Version spéciale pour fers très courbés
- 
 Integrierte Absturz- und Auflaufsicherung
 Integrated derailment and bumping protection
 Avec anti-chute et anti-basculement
- 
 Verzinkte Lastbolzen, Einstellscheiben
 und Befestigungsmuttern
 Zinc plated load bars, washers and locking nuts
 Traverses, entretoises et bagues zinguées
- 
 Deutsche Herstellung
 Manufactured in Germany
 Fabrication Européenne



Tragfähigkeit	Flanscbreite von - bis bei Lastbolzengröße		Kurvenradius min.	Gewicht
Capacity	Flange width from - to for load bar size		min. curve radius	Weight
Capacité	Largeur de fer de - à pour traverse		Radius de courbe min.	Poids
kg	1N mm	2N mm	m	ca. kg approx. kg env. kg
1000	50 - 180	181 - 300	0,65	35
2000	50 - 170	171 - 300	0,70	50
3200	66 - 170	171 - 300	0,75	80
6300	74 - 170	171 - 300	0,80	125
10000	119 - 160	161 - 300	0,95	235
15000	130 - 220	221 - 300	1,50	380
20000	130 - 220	221 - 300	1,20	555
32000	160 - 300	-	2,25	750

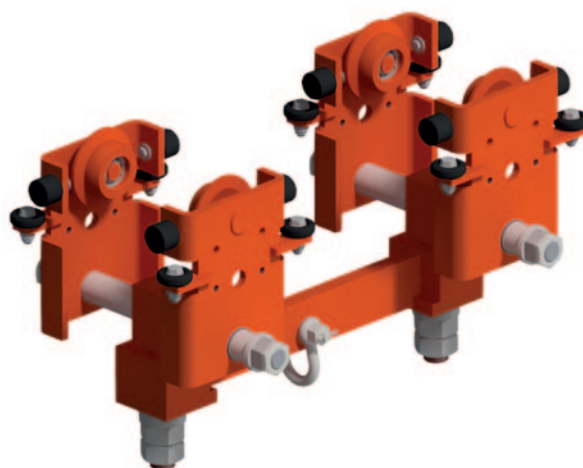

HADEF

32/20 R

Drehschemel-Rollfahrwerk/ Swivelling Push Travel Trolley
Chariot boogie à pousser

ISO 9001
certified company

PREMIUM LINE

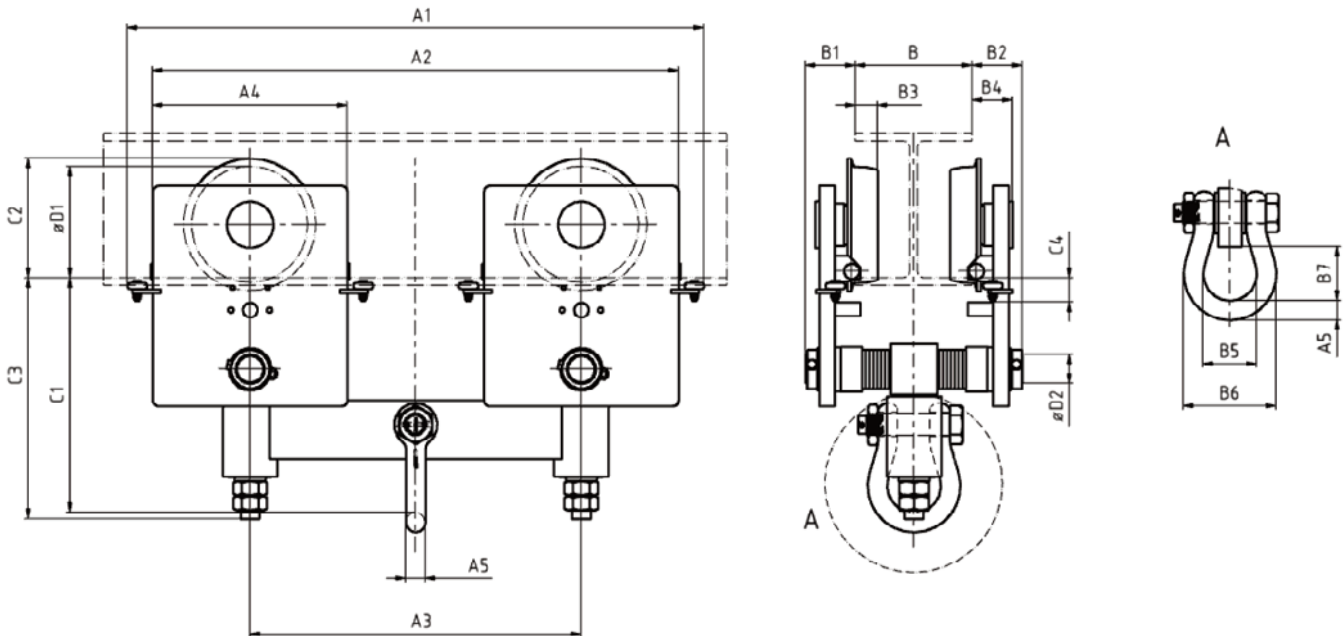

Tragfähigkeit Capacity Capacité kg	Lastbolzen Load bar Traverse Größe size taille	Hauptabmessungen in mm Main dimensions in mm Dimensions principales en mm																		
		A1	A2	A3	A4	A5	B 1/2 ⁽¹⁾	B3	B4	B5	B6	B7	C1	C2	C3	C4	D1	D2		
		1000	1 N 2 N	790	685	500	185	11	175 130	19	32	29	51	32	262	78	286	38	65	18
		2000	1 N 2 N	792	689	510	179	16	180 189	21	35	43	75	51	304	78	326	38	65	24
3200	1 N 2 N	825	735	535	200	16	133 143	23	44	43	75	43	322	99	381	44	83	30		
6300	1 N 2 N	904	830	580	250	22	145 158	26	53	58	102	58	364	134	396	41	118	36		
10000	1 N 2 N	1095	965	665	300	32	131 222	39	69	83	147	83	470	168	520	45	150	39		
15000	1 N 2 N	1370	1240	840	400	38	226 210	44	85	99	175	38	517	219	551	45	198	48		
20000	1 N 2 N	1420	1290	840	450	45	226 210	48	103	126	216	126	549	269	556	45	248	48		
32000	1 N 2 N	1480	1350	850	500	50	199 -	57	103	138	238	138	589	319	605	50	298	75		

(1) Maximales Außenmaß bei kleinster Flanschbreite/ max. outside dimension with smallest flange width/ max. dimension extérieure pour largeur de fer minimale



HADEF

32/20 R

Drehschemel-Rollfahrwerk/ Swivelling Push Travel Trolley
Chariot boogie à pousser

ISO 9001
certified company

PREMIUM LINE



Optionen/ Options / Options

größere Flanschbreiten möglich
larger flange width available
largeur de fer plus grande possible



Begrenzungspuffer
End stops
Butées caoutchouc

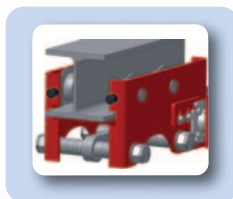

Ausführung **ATEX**
version
version